

Gebrauchs- und Montageanleitung
Operating and installation instructions

E-Komfortdurchlauferhitzer DEX Next

E-convenience instant water heater DEX Next



de	>	2
en	>	22
fr	>	41
nl	>	61
pt	>	80
es	>	99
pl	>	118
ru	>	137
cs	>	157
sk	>	176
bg	>	195
sr	>	214



Operation instruction

1. Description of the appliance	23
2. Environment and recycling	23
3. How to use	24
Main screen.....	24
Main menu.....	25
Statistics	25
Settings	25
User	27
Device Information	27
Top-up heating	27
How to save energy.....	27
Venting after maintenance work.....	27
Cleaning and maintenance.....	27
4. Trouble-shooting and service.....	28
5. Product data sheet in accordance with EU regulation - 812/2013 814/2013	29

Installation instruction

1. Overview.....	30
2. Technical specifications	31
3. Dimensions	31
4. Installation.....	32
Installation site	32
Mounting accessories	32
Installing the wall bracket.....	33
Installing connection pieces.....	33
Installing the appliance	34
5. Direct connection	35
6. Electrical connection	36
Wiring diagram.....	36
Structural prerequisites	36
Load shedding relay.....	36
Electrical connection from below.....	37
Electrical connection from above.....	37
7. Initial operation	38
Selection of power rating.....	38
Reinstallation	38
Shower application	39
Locking function	39
8. Maintenance work.....	40
Cleaning and replacing the filter strainer	40
Cleaning and replacing the filter strainer if direct connected.....	40

The documents supplied with the device must be stored carefully.

Registration

Register your device online on our website and benefit from our services under warranty.

Your full details help our customer service process your request as fast as possible.

For online registration, just follow the link below or use the QR code with your smartphone or tablet.

<https://partner.clage.com/en/service/device-registration/>



Operation instruction

Note: Carefully read the enclosed safety instructions through in full before the appliance is installed, put into service and used and follow them in the further steps and during use!

EN

1. Description of the appliance



The E-convenience instant water heater DEX Next is a fully electronically controlled instantaneous water heater with graphics-enabled e-paper display and sensor keys for a convenient and efficient water supply to one or more tap outlets.

Its electronic control regulates the power consumption depending on the selected outlet temperature, the respective inlet temperature and the flow rate, thus reaching the set temperature exactly to the degree and keeping it constant in case of water pressure fluctuations. The required outlet temperature can be entered via the sensor keys within a range between 20 °C and 60 °C and can be read off the e-paper display.

The DEX Next has an intuitive menu guide where different user profiles can be set up and where collected data can be read out

The inlet temperature can be up to 70 °C so that operation in connection with reheating, e.g. in solar systems, is possible.

It is possible to use the instantaneous water heater in combination with an external load shedding relay for electronically controlled instantaneous water heaters (refer to installing instructions).

As soon as you open the hot water tap, the instantaneous water heater switches on automatically. When the tap is closed, the appliance automatically switches off. The water heater is operated at the device itself or with an optional wireless remote control.

2. Environment and recycling

This product was manufactured climate neutrally according to Scope 1 + 2. We recommend the purchase of 100% green electricity to make the operation climate neutral as well.

Disposal of transport and packaging material: For smooth transport your product is carefully packed. The disposal of the transport material is carried out by the specialist tradesman or the specialist trade. Separate the sales packaging according to materials separated according to materials via one of the dual systems in Germany.

Disposal of old products: Your product was manufactured from high-quality, reusable materials and components. Products marked with the crossed-out wheeled bin symbol must be disposed of separately from household waste at the end of their service life. Therefore, take this product to us as the manufacturer or to one of the municipal collection points that recycle used electronic devices. This proper disposal serves to protect the environment and prevents possible harmful effects on humans and the environment that could result from improper handling of the products at the end of their service life. For more detailed information on disposal, please contact your nearest collection point or recycling centre or your local council.

Business customers: If you wish to discard equipment, please contact your dealer or supplier for further information.

For disposal outside Germany, please also observe the local regulations and laws.

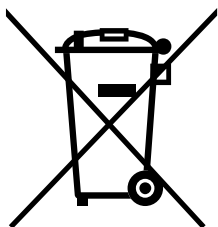

Main screen

The e-paper display changes automatically to main screen approx. 60 seconds after activation or operation.

Tab the sensor keys to select user profiles or applications or change the temperature.

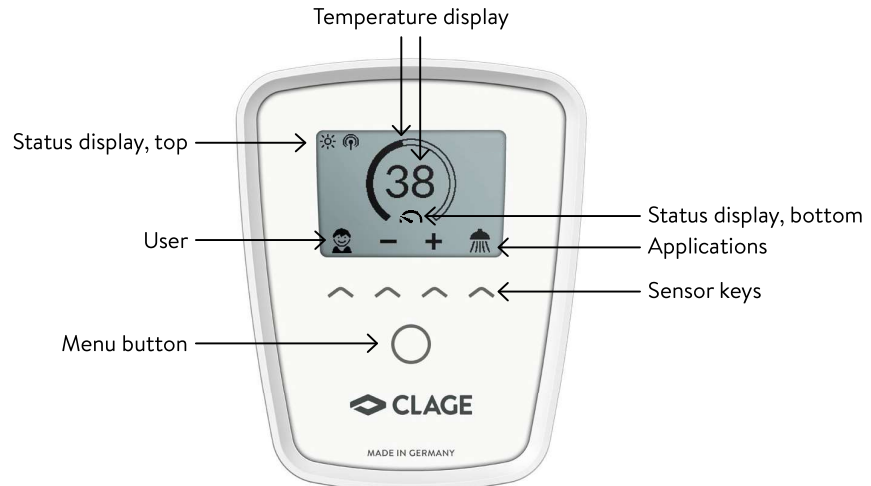

Temperature display

The scale ring fills up as the temperature setting is increased. In addition, the target temperature is displayed in °C in the middle of the display.

Temperature setting

The desired temperature can be selected via the two middle sensor keys within a range of 20 °C to 60 °C. Tapping once changes the temperature by 1 °C, in the comfort range between 35 and 43 °C by 0.5 °C. If the temperature is set below 20 °C, the symbol — appears in the temperature display and the appliance switches off the heating function.

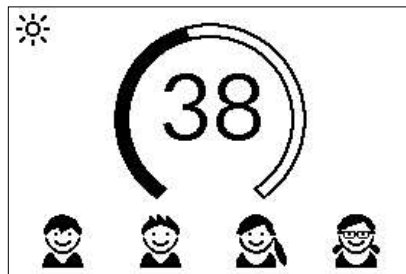

User selection

Up to four user profiles can be created. Every user has the option to save his desired temperatures for the different application in his profile. The user profiles can be selected by tapping on the left sensor key and then tap the key under the profile picture (to adapt profile, see Section “User”).

Applications

Preset applications can be selected here. Simply tap on the right sensor key to open the selection. Tap on the sensor key under an application symbol to activate it.

The temperatures are set at the factory to the following values: hand wash = 35 °C, shower = 38 °C, bath tub = 40 °C, hot water = 48 °C

To change the values select an application and set the new temperature. Then press and hold the sensor key under your profile picture or the application for two seconds.

Status display, top

- Control lock active (PIN)
- The inlet temperature exceeds the target value (appliance does not heat up)
- Optional remote control or Home Server is installed. The appliance can be controlled remotely



Status display, bottom

Display area for functions which require confirmation from the user or which are of great significance.

- Maintenance: The appliance detected an error. Select “Info” in the Main menu to get further informations.

3. How to use

EN

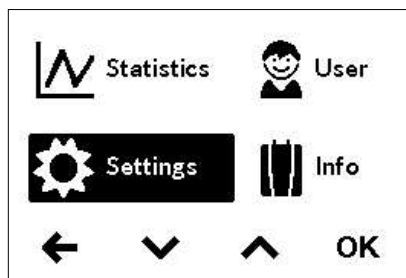

- MAX** Maximum temperature reached: The temperature cannot be increased any further since the set temperature limit has been reached. The temperature limit can be changed in the main menu via “Settings”.
-  Heating activated: As soon as the appliance heats water, this symbol appears.
-  Power limit: The full output of the instantaneous water heater does not suffice to heat the tapped quantity of water to desired temperature. Reduce the quantity of warm water at the tap.



**Main menu**

Press the menu button to enter the main menu. All function menus and saved values of the appliance can be selected from here.

Statistics

In the statistics the consumption and usage data are captured by the appliance and displayed in graph format:



-  Water consumption
-  Power consumption
-  Total consumption costs

Select  or  to scroll through the different periods. The consumptions are displayed in diagrams over a period from the last drawing of water or the total consumption.

Note: The consumption data are not suitable for billing purposes.

Consumption last tapping	
Σ 0.52 €	Duration 2m30s
Water 65.4 l	
Power 0.9 kWh	

Settings

This menu is used for the basic configuration on the appliance. Select  or  to scroll through the different menu items and tap “OK” to change settings directly or go to submenus.

Temperature Unit: Defined as °C.

Language: Select the menu language.

Sound: Activate / deactivate operating sounds.

Note: Alarm signals and instruction sounds can not be disabled.

Currency: Select a currency symbol.

 Temperature Limit	60.0 °C
Operation Lock	OFF
Electr. Tariff (€/kWh)	0.28€
Water Tariff (€/m ³)	4.00€
Load Shedding	0

Temperature Limit: The temperature limit can be activated / deactivated in this menu and the maximum warm water temperature can be limited to a desired value within the temperature setting range.

Note: If the instantaneous water heater supplies a shower, then the maximum temperature was limited during the installation of the appliance and can not be changed.

Operation Lock: Secure your settings with a four-digit PIN.

Note: The operation lock can only be deactivated with the correct PIN under “Protected Sections” or under “Delete PIN”. If you should forget your PIN, please contact Customer Services.

PIN Entry: Use \blacktriangle or \blacktriangledown to select digits from 00 to 99. To move to the next or previous digit, select \blackleftarrow or \blackrightarrow . Once you have selected both digits, confirm by \blackrightarrow . The PIN must be reentered and confirmed by “OK” as a security measure.

If both entries match, the range of the control lock can be set.

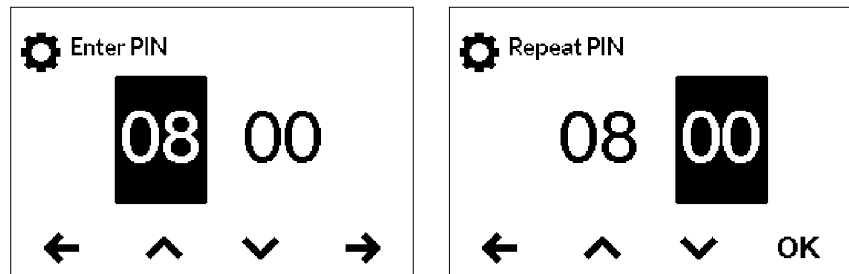

- Settings: Automatically active as soon as a password has been generated. Users can only access the settings menu with a PIN.
- All: PIN entry is required to operate the appliance.
- OFF: The PIN is deleted and the appliance can be operated freely.

Electricity price (currency/kWh): Specify the electricity price of your own electricity supplier.

Water price (currency/m³): Specify the water price of your own water supplier.

Value	Description
0	Operation without load shedding relay, factory setting
1	Operation with normal load shedding relay
2	Operation with sensitive load shedding relay

Load Shedding: If further three-phase appliances are connected, a load shedding relay designed for electronic instantaneous water heaters (CLAGE no. 82250) can be connected to phase conductor L2. This relay ensures the operation of the water heater by switching off other consumers until the end of heating operation.

Select “OK” to activate the edit mode. To set a value of “0”, “1” or “2” press and hold \blacktriangle or \blacktriangledown for two seconds.

Operating mode 1 must be selected first, thus to check the correct operation of the load shedding relay at low appliance output (35 degree celsius setpoint and low water flow rate). Mode 2 must be selected if the load shedding relay flickers.

Factory Settings: All factory settings can be recalled. Temperature limit for showering and load shedding are not affected.

Note: All customised user profiles and power and water prices entered, are deleted.

Delete Statistics: Use this function to delete all previously collected statistical data. Deleted statistical data cannot be restored.

3. How to use

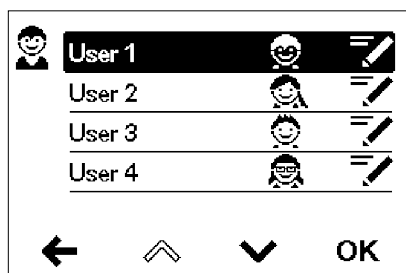

User

Each of the four user profiles can be provided with their own profile image. This image appears in the main screen.

In the main screen, every user can set up and save his own desired temperatures for the different applications.

EN

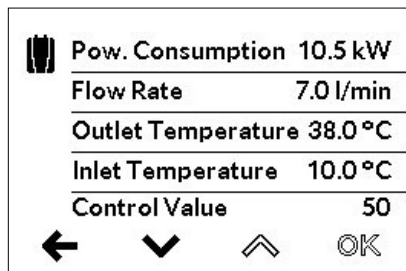

Device Information

The current status and appliance data are listed here. Use the sensor keys to scroll through the different information values.

Top-up heating

When operating with preheated water (e.g. with solar systems), you must ensure that the inlet temperature does not exceed 70 °C.

If the inlet temperature exceeds the setpoint, the appliance is not providing any output. The symbol ☀ is displayed in the main screen

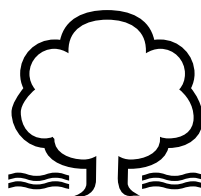

How to save energy

Set the exact temperature you need on the appliance and open the hot water tap. Once you feel that the water is too hot, do not add any cold water and, instead, enter a lower temperature on the appliance. If you were to add cold water, the water already heated would cool down again and valuable energy would be wasted. Moreover, the cold water added in the tap is not covered by the control range of the electronic circuitry, with the result that temperature constancy is no longer guaranteed.



Venting after maintenance work

This instantaneous water heater features an automatic air bubble protection to prevent it from inadvertently running dry. Nevertheless, the appliance must be vented before using it for the first time. Each time the appliance is emptied (e.g. after work on the plumbing system, if there is a risk of frost or following repair work), the appliance must be re-vented before it is used again.

1. Disconnect the instantaneous water heater from the mains (e.g. via deactivating the fuses).
2. Unscrew the jet regulator on the outlet fitting and open the cold water tap valve to rinse out the water pipe and avoid contaminating the appliance or the jet regulator.
3. Open and close the hot water tap until no more air emerges from the pipe and all air has been eliminated from the water heater.
4. Only then should you re-connect the power supply again (e.g. via activating the fuses) to the instantaneous water heater and screw the jet regulator back in.
5. The appliance activates the heater after approx. 10 seconds of continuous water flow.

Cleaning and maintenance

- Plastic surfaces and fittings should only be wiped with a damp cloth. Do not use abrasive or chlorine-based cleaning agents or solvents.
- For a good water supply, the outlet fittings (e.g. jet regulators and shower heads) should be unscrewed and cleaned at regular intervals. Every three years, the electrical and plumbing components should be inspected by an authorised professional in order to ensure proper functioning and operational safety at all times.

4. Trouble-shooting and service

EN



Repairs must only be carried out by authorised professionals.

If a fault in your appliance cannot be rectified with the aid of this table, please contact the service organisation of your importer or the Central Customer Service Department. Please have the details of the typeplate at hand.

CLAGE GmbH



After-Sales Service

Pirolweg 4
21337 Lüneburg
Germany

Phone: +49 4131 8901-400

Email: service@clage.de

This instantaneous water heater was manufactured conscientiously and checked several times before delivery. Should malfunctions nevertheless occur, it is usually only due to a bagatelle. First attempt to switch the house fuses off and on again in order to reset the electronics. Next, try to remedy the problem with reference to the following table. In doing so, you will avoid unnecessary expense of customer service assistance.

DEX Next		
Problem	Cause	Solution
Water stays cold, touch display shows power break screen 	Master fuse tripped	Renew or activate fuse
	Safety pressure cut-out tripped	Contact customer service
Water stays cold, display shows error symbol 	The appliance has detected an error	Switch fuses off and on. If symbol "wrench" is still indicated, contact customer service
Flow rate of hot water too weak	Outlet fitting dirty or calcified	Clean shower head, jet regulator or sieves
	Fine filter dirty or calcified	Let clean fine filter by customer service
Selected temperature is not reached	Power limit reached	Decrease the warm water flow at the tap
	Cold water has been added via the tap	Tap hot water only; set temperature, check outlet temperature
Sensor keys does not respond correctly or only sporadically	Display glass is wet	Dry display by wiping it with a soft cloth

5. Product data sheet in accordance with EU regulation - 812/2013 814/2013

a	b		c	d	e	f	h	i
	b.1	b.2						
CLAGE	DEX Next	5E-270P-3D	S	A	η_{WH} %	AEC kWh	°C	L_{WA} dB(A)
					38	482	60	15

EN

Explanations

a	Brand name or trademark
b.1	Model
b.2	Type
c	Specified load profile
d	Energy-efficiency class
e	Energy-efficiency
f	Annual power consumption
g	Additional load profile, the appropriate energy-efficiency and the annual power consumption, if applicable
h	Temperature setting for the temperature controller
i	Sound power level, internal

Additional notes



All specific precautions for assembly, installation, maintenance and use are described in the operating and installation instructions.



All data in this product data sheet are determined by applying the specifications of the relevant European directives. Differences to other product information listed elsewhere may result in different test conditions.

The power consumption was determined in compliance with standardized measurement method based on EU guidelines. The real energy consumption is pending on individual requirements.

Installation instruction

1. Overview

EN

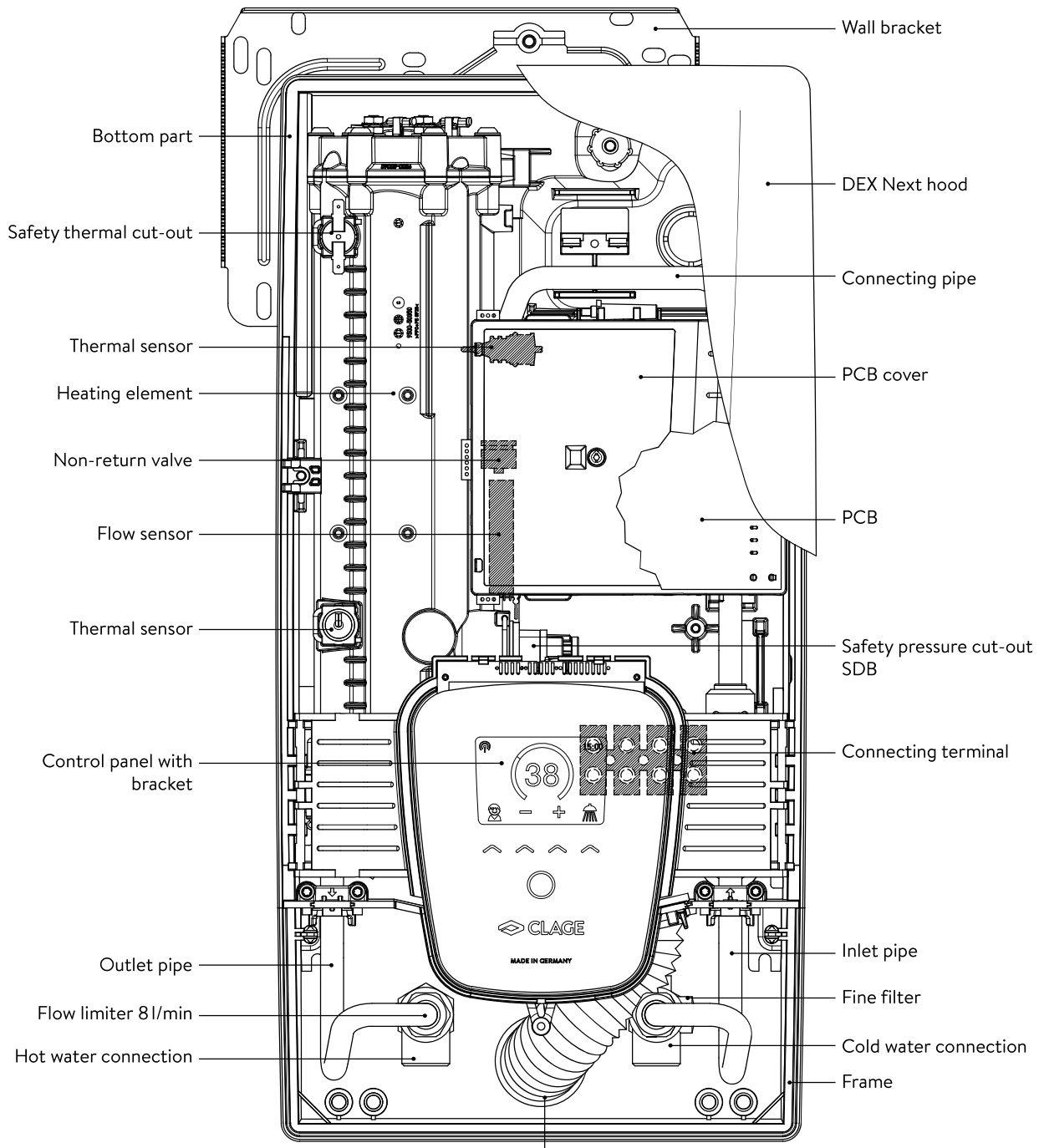

Screw-in nipples 1/2 inch



Grommet

2. Technical specifications

Model	DEX Next			
Energy efficiency class	A *)			
Rated capacity / rated current	18 kW..27 kW (26 A..39 A)			
Chosen capacity / current	18 kW / 26 A	21 kW / 30 A	24 kW / 35 A	27 kW / 39 A
Electrical connection	3~ / PE 380..415 V AC			3~ / PE 400 V AC
Min. required cable size ¹⁾	4.0 mm ²	4.0 mm ²	6.0 mm ²	6.0 mm ²
Hot water (l/min) max. at $\Delta t = 28$ K max. at $\Delta t = 38$ K	9.2 ²⁾ 6.8	10.7 ²⁾ 7.9	12.3 ²⁾ 9.0 ²⁾	13.8 ²⁾ 10.2 ²⁾
Rated volume	0.4 l			
Rated pressure	1.0 MPa (10 bar)			
Connecting type	pressure-resistant / pressureless			
Heating system	Bare wire heating system IES®			
@ 15 °C: Required specific water resistance Specific electrical conductivity	$\geq 1100 \Omega\text{cm}$ $\leq 90 \text{ mS/m}$			
Inlet temperature	≤ 70 °C			
Flow rate to switch on – max. flow rate	1.5 l/min – 8.0 ³⁾			
Pressure loss	0.08 bar at 1.5 l/min 1.3 bar at 9.0 l/min ⁴⁾			
Temperature range	20 – 60 °C			
Water connection	G ½ inch			
Weight (when filled with water)	4.2 kg			
VDE class of protection	I			
Type of protection / safety	 IP25 CE			

*) The declaration complies with the EU regulation No 812/2013.

1) Maximum applicable cable size is 10 mm² at electrical connection from above

2) Mixed water

3) Flow rate limited to achieve optimum temperature rise

4) Without flow regulator

3. Dimensions

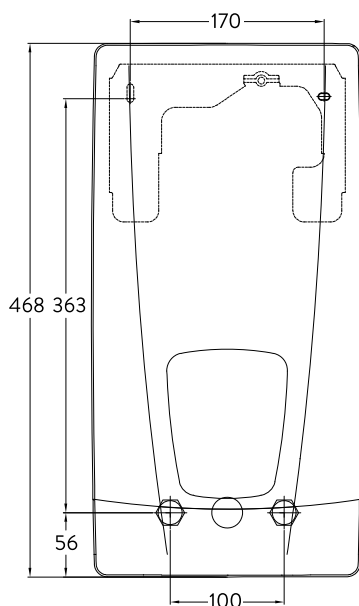

Dimensions in mm

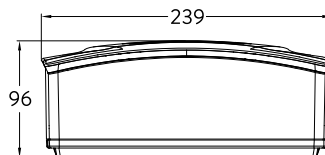

4. Installation

EN



Based on the national constitution guidelines a general test certificate concerning the evidence of applicability of noise behaviour is granted.

The following regulations must be observed:

- e.g. VDE 0100
- EN 806
- Installation must comply with all statutory regulations, as well as those of the local electricity and water supply companies.
- The rating plate and technical specifications
- Only intact and appropriate tools must be used

Installation site

- Appliance must only be installed in frost-free rooms. Never expose appliance to frost.
- The Appliance must be wall mounted and has to be installed with water connectors downward or alternative transversely with water connections left.
- The appliance complies with protection type IP25 and may therefore be installed in protection zone 1 according to VDE 0100 part 701 (IEC 60364-7).
- In order to avoid thermal losses, the distance between the instantaneous water heater and the tap connection should be as small as possible.
- The appliance must be accessible for maintenance work.
- Plastic pipes may only be used if they conform to DIN 16893, Series 2.
- The specific resistance of the water must be at least $1100 \Omega \text{ cm}$ at 15°C . The specific resistance can be asked for with your water distribution company.

Mounting accessories

For installations under difficult conditions, these mounting accessories are available:

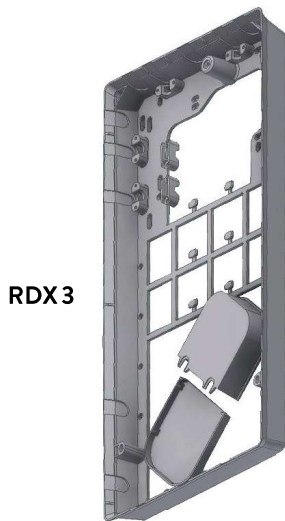

RDX3

Mounting frame kit RDX3

(Art. no. 36100)

The instant water heater can be installed by means of this mounting kit in the below situations. The power supply cable is coming out of the wall at any place from behind the unit, but the wall has unusual surface conditions, making it difficult for installing the water heater.

When using the RDX the protection class changes from IP25 to IP24.

VDX

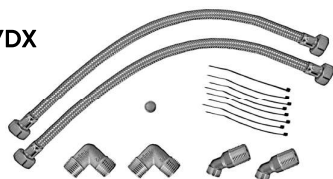

Extension kit VDX

(Art. no. 34120) – RDX / RDX3 is necessary! –

The instant water heater can be installed by means of this extension kit if the water pipes are coming displaced or exchanged out of the wall or if they are coming edge-wise on the wall to the unit. The power supply could come out of the wall at any place under the unit or the wiring could be installed surface-mounted.

UDX

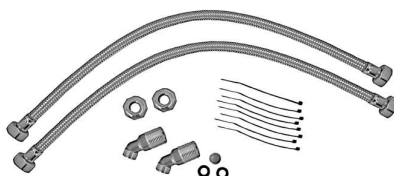

Extension kit UDX

(Art. no. 34110) – RDX / RDX3 is necessary! –

The instant water heater can be installed by means of this extension kit if the water-connections are expiring above the unit. The power supply could come out of the wall at any place under the unit or the wiring could be installed surface-mounted.

4. Installation

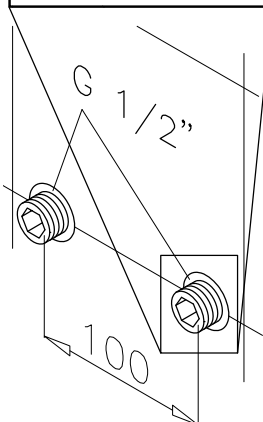
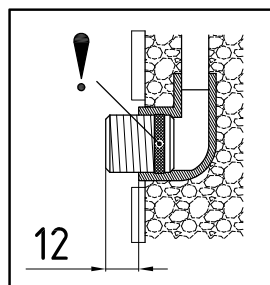
**Installing the wall bracket**

Note: If you install this instantaneous water heater in exchange for a conventional instantaneous water heater, there is generally no need to drill holes for the wall bracket, in this case step 2 would not be necessary.

Thoroughly rinse the water supply pipes before installation to remove soiling from the pipes.

1. Using a 12 mm hexagon socket screw key, screw the screw-in nipples into the wall connections. The seals must be fully screwed into the thread. After tightening, the double nipples must protrude by 12 – 14 mm.
2. Hold the included mounting template on the wall and align it so that the holes in the template fit over the double nipples. Mark the drill holes according to the template and drill them using a 6 mm drill. Insert the included dowels.
3. Pull down the faceplate and unscrew the main hood screw to open the appliance.
4. Loosen the knurled nut to remove the wall bracket and screw the wall bracket to the wall. Offset tiling or uneven surfaces can be compensated by up to 30 mm with the aid of the spacers supplied. The spacers are fitted between the wall and the wall bracket.

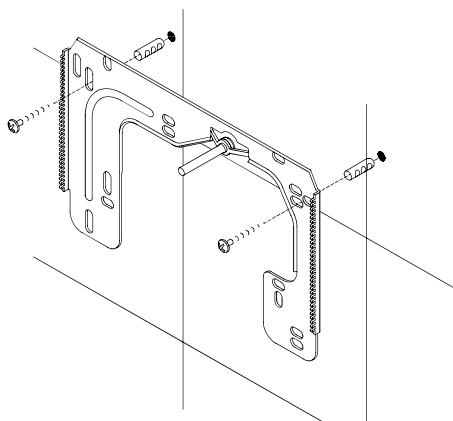
**Installing connection pieces**

Note: Fasten the screw nuts with caution, to avoid damage to the valves or the piping system.

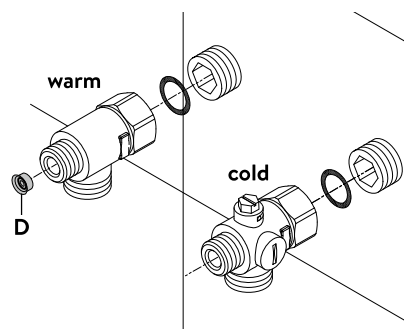

- As shown in the illustration, screw the cold water connection piece with the union nut and the ½ inch seal onto the cold water connection.
- Screw the hot water connection piece with the union nut and the ½ inch seal onto the hot water connection.
- Put the water flow reducer “D” into the hot water connection piece.

4. Installation

EN

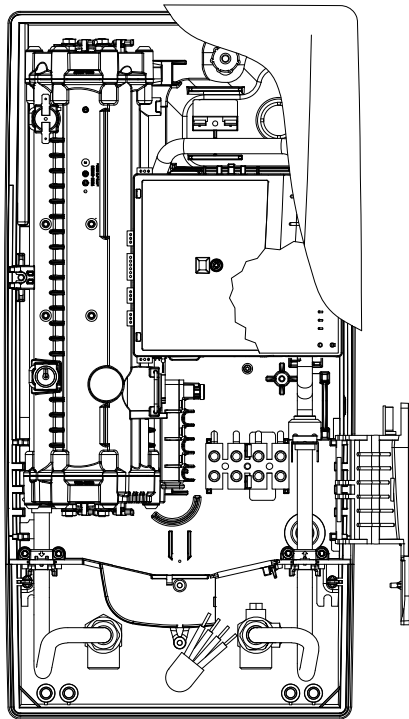

Installing the appliance

- The electrical power supply cable may be connected in the upper part or is surface mounted. Only in such case, first follow the steps one through three according to the description “Electrical connection from above” in chapter “Electrical connection”.
1. Place the appliance on the heater bracket so that the threaded rod of the wall bracket fits in the corresponding hole of the appliance. If necessary, slight corrections are possible by carefully bending the threaded rod of the wall bracket. However, it must be possible to screw on the water connection pipes of the appliance without applying force.
 2. Screw the plastic knurled nut onto the threaded rod of the wall bracket.
 3. Screw the two $\frac{3}{8}$ inch union nuts of the appliance's water connection pipes, each with the $\frac{3}{8}$ inch seal, onto the fittings.

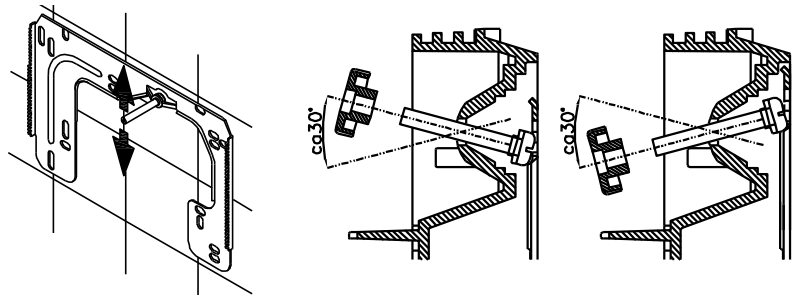

4. Open the water supply line to the unit and slowly open (position “open”) the shut-off valve (a) in the cold water connection piece. Check all connections for leaks.
5. Next, open and close the hot water tapping valve several times until no more air emerges from the line and all air has been eliminated from the instantaneous water heater.

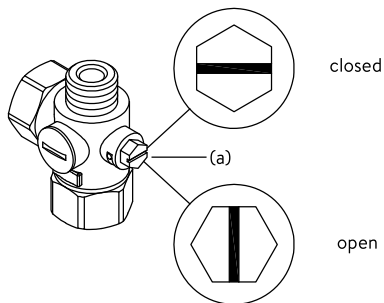

5. Direct connection

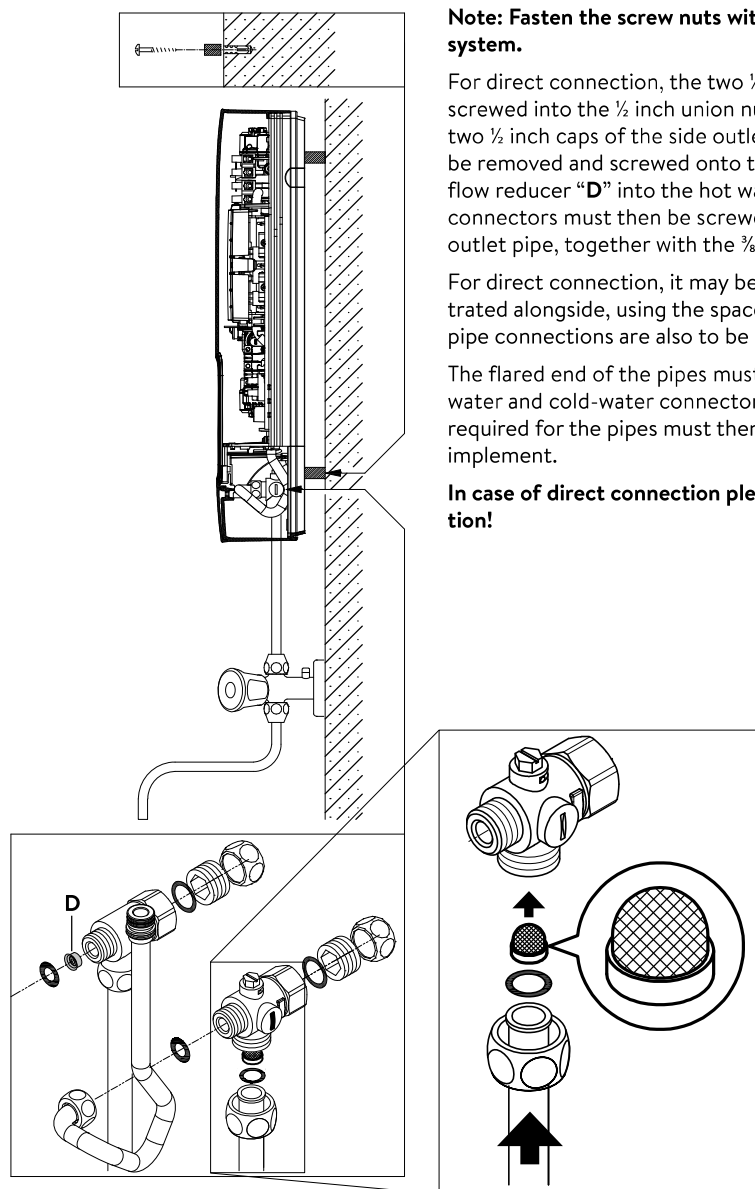

Note: Fasten the screw nuts with caution, to avoid damage to the valves or the piping system.

For direct connection, the two ½ inch screw-in nipples and the ½ inch seals must be screwed into the ½ inch union nuts of the hot-water and cold-water connectors. The two ½ inch caps of the side outlets of the hot-water and cold-water connectors must be removed and screwed onto the open end of the screw-in nipples. Put the water flow reducer “D” into the hot water connection piece. The hot-water and cold-water connectors must then be screwed into the ¾ inch union nut of the appliance inlet and outlet pipe, together with the ¾ inch seals.

For direct connection, it may be advisable to mount the appliance at a distance as illustrated alongside, using the spacer sleeves supplied. The two fixing holes near the lower pipe connections are also to be professionally fixed with 6 mm dowels and screws.

The flared end of the pipes must be screwed into the ½ inch side outlets of the hot-water and cold-water connectors with ½ inch union nuts and ½ inch seals. The holes required for the pipes must then be opened of the housing with the aid of a blunt implement.

In case of direct connection please note: Put the strainer into the cold water connection!

6. Electrical connection

Wiring diagram

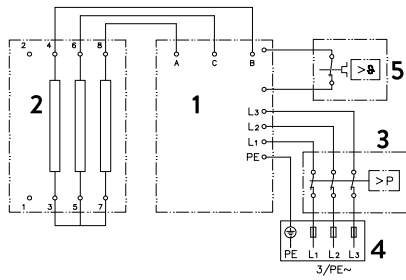

1. Electronic circuitry
2. Heating element
3. Safety pressure cut-out
4. Connecting terminal
5. Safety thermal cut-out

Only by a specialist!

Please observe:

- e.g. VDE 0100
- The installation must comply with current IEC and national local regulations or any particular regulations, specified by the local electricity supply company
- The rating plate and technical specifications
- The appliance must be earthed!

Structural prerequisites

- The appliance must be installed via a permanent connection. Heater must be earthed!
- The electric wiring should not be injured. After mounting, the wiring must not be direct accessible.
- An all-pole disconnecting device (e.g. via fuses) with a contact opening width of at least 3 mm per pole should be provided at the installation end.
- To protect the appliance, a fuse element must be fitted with a tripping current commensurate with the nominal current of the appliance.

Load shedding relay

If further three-phase appliances are connected, a load shedding relay designed for electronic instantaneous water heaters (CLAGE no. 82250) can be connected to phase conductor L2.

To change the operating mode, after making the electrical connection and the initial operation call up the settings menu. Then select the point "Load shedding".

Select "OK" to access the edit mode. To set a value of "0", "1" or "2" press and hold ▲ or ▼ for two seconds. By plugging the jumper in accordance with the locking function (see chapter »7. Initial operation« section »Locking function«) the load shedding is activated.

Value	Description
0	Operation without load shedding relay, factory setting
1	Operation with normal load shedding relay
2	Operation with sensitive load shedding relay

Operating mode 1 must be selected first, thus to check the correct operation of the load shedding relay at low appliance output (35 degree celsius setpoint and low water flow rate). Mode "2" must be selected if the load shedding relay flickers.

6. Electrical connection

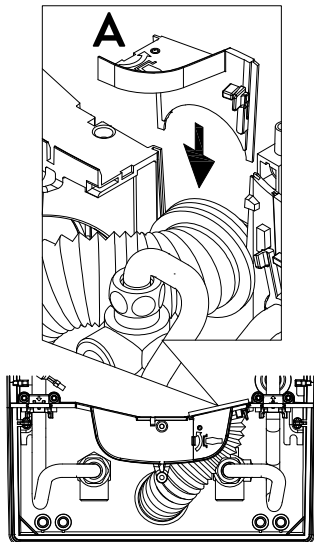
**Electrical connection from below**

Note: If necessary, the connecting terminal can be displaced to the upper part of the appliance. If you want to do so, please follow the instructions in the next chapter.

Check that the power supply is switched off prior to electrical connection!

1. Dismantle approximately 6 cm off the connecting cable above the wall outlet. With the smaller opening ahead, slide the water splash protection sleeve over the connecting cable so that the sleeve is flush with the wall. This prevents any leaking water from coming into contact with the electrical leads. It must not become damaged! **The protection sleeve must be used!**
2. Open the control panel holder rightwards.
3. Strip the cables and plug them in the connecting terminals according to the wiring diagram. **The appliance must be earthed.**
4. Pull the protective sleeve over the connecting cables until the sleeve fits perfectly in the recess of the intermediate panel. Adjust the water splash protection sleeve as illustrated and fix it with the sleeve fixing (A). Reinsert the control panel holder and lock it on.
5. Place the hood on the appliance and screw in the fastening screw. After that you can slide on the faceplate from the bottom up to the stop.

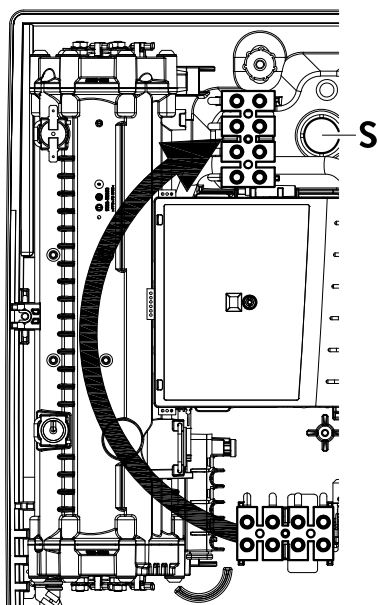
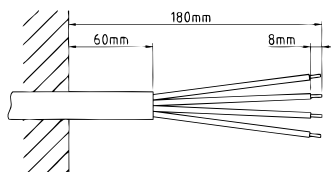
**Electrical connection from above**

Check that the power supply is switched off prior to electrical connection!

1. Open the prepared breaking point (S) in the upper part of the appliance by pressing with a blunt implement (e.g. screwdriver). For surface-mounted connection cable additional open the breakout at the right side of the bottom part.
2. Slit the grommet of the accessory set to match the cable size. The opening in the grommet should be slightly smaller than the cross-section of the cable in order to ensure optimum protection against water. Fit the grommet into the opening. **The protection grommet must be used!**
3. Strip the connection cable so that the sheath extends through the grommet into the appliance. Hold the prepared appliance so that you can route the cable into the grommet with the other hand.
4. Place the appliance on the wall bracket so that the threaded rod of the wall bracket fits in the corresponding hole of the appliance.
5. Open the control panel.
6. Unscrew the fastening screw of the connecting terminal. Displace the connecting terminal to the upper foot. Affix the connecting terminal again.
7. Strip the individual wires and plug them in the connecting terminals according to the wiring diagram. **The appliance must be earthed.**
8. Reinsert the control panel and lock it on.
9. Place the hood on the appliance and screw in the fastening screw. After that you can slide on the faceplate from the bottom up to the stop.

Note: To ensure IP25 protection class, please don't remove the bottom water splash protection sleeve.

7. Initial operation

EN

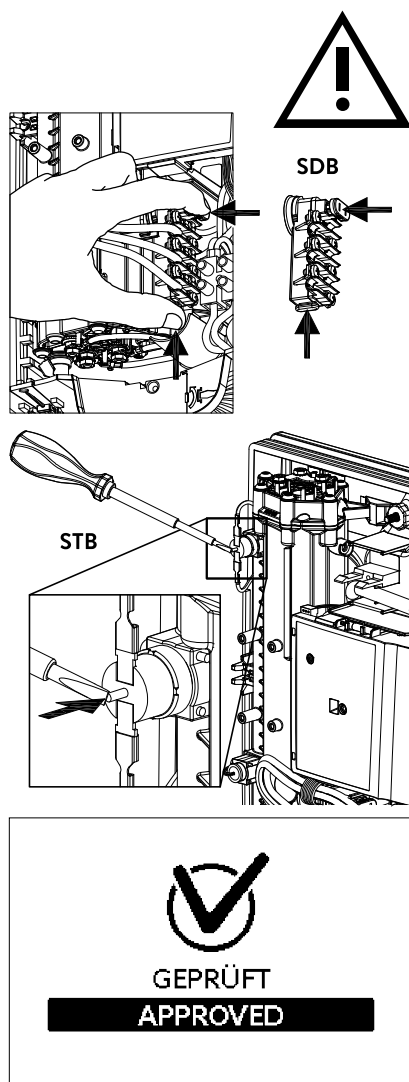
**Multiple Power System MPS®:**

The rated capacity (max. power consumption) is 27 kW / 400 V and can be changed internally to 24 kW, 21 kW or 18 kW.

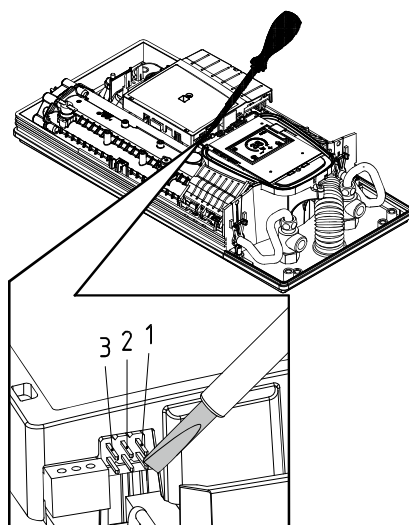

Before making the electrical connection, fill the mains and the appliance with water by carefully opening and closing the hot water tap in order to vent completely.

To ensure a maximum flow, remove any existing aerator from the faucet. Flush the warm and cold water pipes each at least for one minute.

After every draining (e.g. after work on the plumbing system or following repairs to the appliance), the heater must be re-vented in this way before starting it up again.

If the water heater cannot be put into operation, the temperature cut-out or the pressure cut-out may have tripped during transport. Check that the power supply is switched off and reset the cut-out, if necessary.

Selection of power rating

Only by authorised specialist, otherwise lapse of guarantee!

On delivery, the display shows the screen "APPROVED" (see left). If not, the device has already been powered once. In this case, please follow the section "Reinstallation".

Upon first connection of the appliance to the supply voltage, select the maximum power rating. Only after having set the power rating, the heater provides its standard operation mode.

The maximum allowable power rating at installation site depends on the local situation. It is imperative to observe all data shown in the table "Technical specifications", in particular the required cable size and fuse protection for the electrical connection. Moreover, the electrical installation must comply with the statutory regulations of the respective country and those of the local electricity supply company (Germany: DIN VDE 0100).

1. Switch on the power supply to the appliance.
2. When switching on the supply voltage for the first time, the display shows the menu to select the language. Choose your language, after that the selection of power rating appears.
3. Select the maximum allowable power rating depending on the local situation via sensor keys (18, 21, 24 or 27 kW).
4. Select "OK" to confirm the setting.
5. Mark the set power rating on the rating plate.
6. After having set the maximum allowable power rating, the heating element will be activated after approx. 10 – 30 sec of continuous water flow.
7. Open the hot water tap. Check the function of the appliance.
8. Explain the user how the instantaneous water heater works and hand over the operating instructions.
9. Fill in the guarantee registration card and send it to the CLAGE After-Sales Service or use the online registration on our website (see also page 22).

Reinstallation

In case the appliance will be commissioned again under different installation conditions than during its initial operation, it may be necessary to adapt the maximum power rating.

A temporary short-circuit of the two pins, e.g. with a screwdriver acc. to EN 60900 (see figure), will reset all heater parameters to works setting and lock the heating. The display shows the menu to select the language. Choose your language, after that the selection of power rating appears. This condition will maintain when activating and deactivating the supply voltage.

7. Initial operation

EN

Shower application

The water heater's temperature must be limited to 55 °C, if it is connected to a shower. The temperature limit must be set to a value less or equal 55 °C in the setting menu, in consultation with the customer and the lock level must be activated.

When the appliance is operated with preheated water, it must be ensured that this temperature is limited to 55 °C as well.

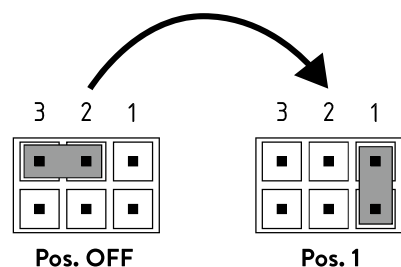
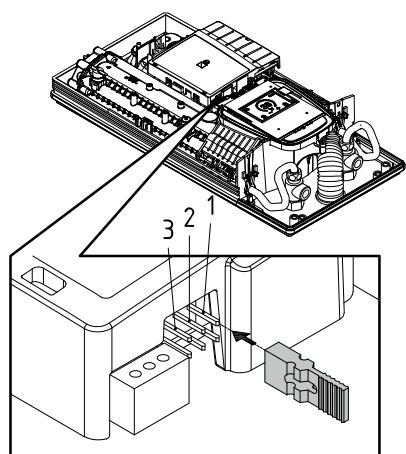

Locking function

The operating mode of the appliance can be restricted.

Activation of the locking function

1. Select required parameters via the setting menu (see online user manual chapter “Settings”, subpoints “Temperature limit” and / or “Load shedding”).
2. Disconnect the appliance from the power supply (e.g. by switching off the fuses).
3. Take the jumper off the power electronics and change to position “1” (see picture).
4. Put the appliance into operation again.

Deactivation of the locking function

1. Disconnect the appliance from the power supply (e.g. by switching off the fuses).
2. Take the jumper off the power electronics and change to position “OFF” (see picture).
3. Put the appliance into operation again.

8. Maintenance work

EN

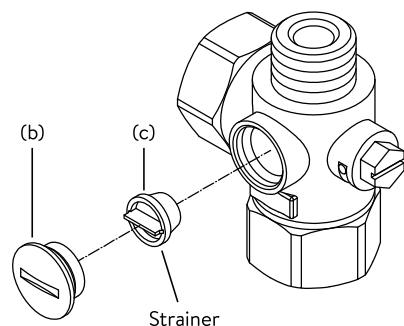
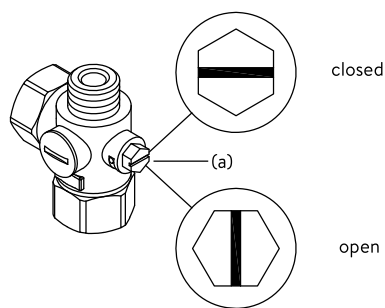

Maintenance work must only be conducted by an authorised professional.

Cleaning and replacing the filter strainer

The cold water connection of this instantaneous water heater is equipped with an integrated shut-off valve and a strainer. Soiling of the strainer may reduce the warm water output. Clean or replace the strainer as follows:

1. De-energize the instantaneous water heater (e.g. via deactivating the fuses) and prevent inadvertent reactivation of them.
2. To open the appliance, take off the small face plate, loose the screw behind this cover and detach the hood.
3. Close the shut-off valve (a) in the cold water connection piece (position "closed").
4. Unscrew the screw plug (b) from the cold water connection piece and take out the strainer (c).
Note: Residual water can leak
5. The strainer can now be cleaned or replaced.
6. After fitting of the clean strainer tighten the screw plug.
7. Slowly reopen the shut-off valve in the cold water connection piece (position "open"). Check all connections for leaks.
8. Vent the appliance by carefully opening and closing the affiliated warm water tap valve several times until air no longer emerges from the pipe.
9. Fit the hood of the appliance. Then switch on the power again (e.g. via activating the fuses).

Cleaning and replacing the filter strainer if direct connected

The cold water connection of this instantaneous water heater is equipped with a strainer. Soiling of the strainer may reduce the warm water output. Clean or replace the strainer as follows:

1. De-energize the instantaneous water heater (e.g. via deactivating the fuses) and prevent inadvertent reactivation of them.
2. Close the shut-off valve in the mains water supply of the instantaneous water heater.
3. To open the appliance, take off the small face plate, loose the screw behind this cover and detach the hood.
4. Unscrew mains water inlet from connection piece and take out the strainer.
Note: Residual water can leak
5. The strainer can now be cleaned or replaced.
6. After refitting the clean strainer reconnect the mains water inlet to the connection piece.
7. Slowly reopen the shut-off valve in the mains water supply. Check all connections for leaks.
8. Vent the appliance by carefully opening and closing the affiliated warm water tap valve several times until air no longer emerges from the pipe.
9. Fit the hood of the appliance. Then switch on the power again (e.g. via activating the fuses).

